

Product Data Sheet

SWS-DI-N4xxx Wireless Digital Input Module



Spinwave Systems' Wireless Digital Input Modules are used to wirelessly monitor dry contacts and make the status available as BACnet, LON or Modbus variables using Spinwave's BMS Protocol Interface or as digital outputs (wireless dry contact replication) using a BMS I/O Interface (SWRF-IOR and SWRF-IOR-D).

The Digital Input Module consists of a high-power radio and a signal conditioning module, mounted inside a NEMA4X fiber glass enclosure. The radio is connected through a standard CAT5 cable to the signal conditioning module, providing data and power to the radio.

The Digital Input Module can be battery or line-powered. A set of 6 D-Cell batteries will last for up to 8 years. The product is suited for both indoor and outdoor applications.

Up to 50 Digital Input Modules can be wirelessly connected to a single BMS protocol gateway. Up to 4 Digital Input Modules are supported by the SWRF-IOR receiver/remote I/O interface.

The SWS-DI-N4PSI (with internal 120VAC/9VDC power supply) also acts as a router/repeater.

Separate wireless Repeaters/Routers are available to cover large indoor or outdoor areas.

Main Features

High reliability wireless sensor network (based on IEEE 802.15.4) outsmarts changing RF interferences with self-adapting frequency agility.

Sophisticated power management results in long battery life; 2 to 8 years, depending on user-selectable transmission interval. Battery health is continuously monitored.

Wide range of sensor and mounting options.

Interfaces to virtually any building automation system, data gateway, PLC or monitoring system.

Sensors can be battery operated or externally powered (9VDC).

Sensor parameters and DDC channel mapping can be easily changed wirelessly.

Applications

Wireless parking lot lighting control.

Wireless pump control.

Wireless equipment status monitoring.

Wireless shade control.

Order Information

SWS-DI-N4BAT: Wireless digital input module in NEMA4X outdoor enclosure with battery holders

SWS-DI-N4PSI: Wireless digital input module in NEMA4X outdoor enclosure with 120VAC/9VDC power supply

SWRF-IOR: Wireless receiver and BMS I/O interface, 4 digital outputs, 4 analog outputs, status output

SWRF-IOR-D: Wireless receiver and BMS I/O interface, 4 digital outputs, status output

SWS-DPC-N4BAT-IOR-D: Configured kit: SWS-DPC-N4BAT, SWRF-IOR-D, SWPSUP-24

SWRP: Wireless router/repeater, extends range

SWRF-xxxx: Wireless receiver/gateway (xxxx: MODBUS-TCP, MODBUS-RTU, BACNET-IP, BACNET-MSTP, LON, SNMP)

Specifications

Enclosure

- SWS-DI-N4BAT: 8"x10"x4" fiber glass
- SWS-DI-N4PSI: 6"x8"x4" fiber glass

Installation

- Surface mount or pole mount

Operating Conditions

- 40°F to 185°F (-40°C to 85°C)
- 5% to 95% R.H. non-condensing

Storage Conditions

- 40°F to 185°F (-40°C to 85°C)
- 5% to 95% R.H. non-condensing

Radio Characteristics

- 2.4GHz, IEEE 802.15.4
- Receiver Sensitivity
-95dBm
- Receiver Adjacent Channel Rejection
+/-5MHz, 46/39 dB
- Receiver Alternate Channel Rejection
+/-10MHz, 58/55 dB
- Open field Range
up to 3500 ft. (1 km)
- Transmission Interval
min. 10 seconds, user configurable

Power

- 3.5VDC to 6VDC, 200mA burst, 250µA average
- Radio will automatically assume repeater/router functionality when powered between 5.5VDC and 9.0VDC

Interfaces

- 1 dry contact input
- DC power connector

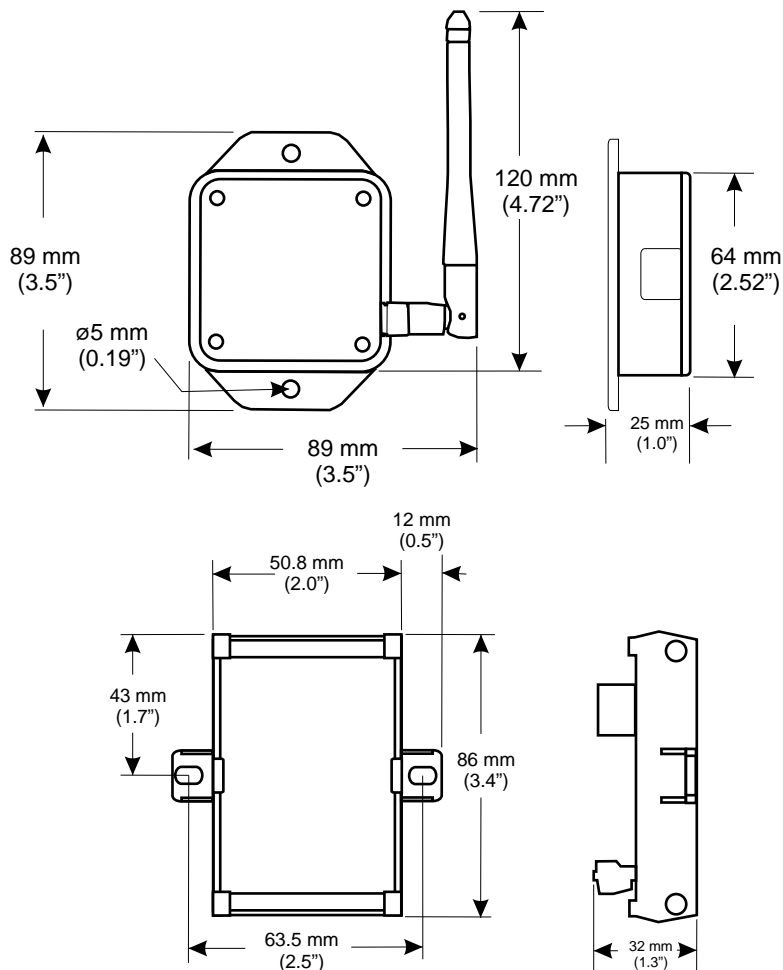

0111C

Spinwave Systems, Inc.
235 Littleton Road
Westford, MA 01886
978-392-9000
www.spinwavesystems.com

© 2011 Spinwave Systems, Inc. All rights reserved.

Spinwave is a trademark of Spinwave Systems, Inc.

All other product and company names are trademarks or registered trademarks of their respective owners.

Specifications are subject to change without notice.